

USER MANUAL FOR: SOL 300



Please read this manual carefully before operating the unit and keep it for reference.

TABLE OF CONTENTS

I SAFETY INSTRUCTIONS.....	3
II CHARACTERISTICS	5
II.1 SWITCHING ON	5
III PARTS DESCRIPTION.....	6
III.1 DEVICE Description.....	6
III.2 CONTROL PANEL:	7
REMOTE CONTROL.....	11
IV.1 GENERAL USE.....	12
IV.2 MP3 DRIVE.....	12
V REPAIRS.....	13
VI QUESTIONS.....	14
VII REGULATION.....	15

Technology to Advance Education

I SAFETY INSTRUCTIONS

Before using the appliance, please read these instructions carefully. Please follow these instructions in order to protect the user and all other person from injury or material damage. Do not execute an operation not indicated in this handbook to avoid any material failure or accidental wound. Moreover any misuse could cause injury or material damage not covered by the guarantee of your appliance.

Keep away the appliance from corrosive substances such as alcohol. It may cause damage to this equipment (fire or electric shock).

Do not place the device on an unstable surface area or in vibrating location. It may fall and cause injury.

Do not place the appliance:

- in humid and dusty location
- in places exposed to smoke or vapour
- in places exposed to snow or rain
- near water or in a wet basement
- under direct sunlight or by heaters such as radiators
- in places submitted to high temperature
- near naked flames

Power-supply cord should be routed so that they are not likely to be walked on or pinched by items placed upon or against it.

Keep the cable away from heaters; the cable may cast and cause fire or electric shock.

Never take hold of the plug or cord with wet hands, you risk exposing yourself to electric shock.

Connect well the cable to the socket, otherwise the cable risks catching fire or causing electric shock.

It is usually recommended to use the cable provided with the appliance to avoid fire or electric shock. If another cable is required, use a model allowed for a voltage of 230V (or 120V). Unroll it totally and plug the power cord into the power cord receptacle of the device and the AC outlet in order to get a perfect connection between both.

Only use the recommended power supply to avoid the risk of fire or electric shock.

When you unplug the appliance, always pull on the socket. If you pull on the cable, you may strip it or break the core of the wire or to corrupt the cable. It would cause current evasions, fire or electric shocks.

Technology to Advance Education

Leave enough space around the power outlet so it can be easily unplugged. If you leave any objects around the outlet, you cannot access it quickly in case of emergency.

Do not attempt to disassemble or modify the device since it contains high voltage and high temperature parts that could ignite or cause electric shocks.

Improper use of electrical equipment is dangerous. To avoid risk of injury, do not let children touch the inside of an electrical appliance or handle the contacts or gears exposed.

If the machine emits unusual noises or smoke, heats or emits an unusual smell, immediately turn off the power. Switch and unplug the electrical outlet. If you continue to use the device in these conditions, it may catch fire or cause electric shocks. Contact the customer service.

Do not spray highly flammable materials near the unit. In contact with the gas emanating from these products, electrical components inside the unit may ignite or cause an electric shock.

Always turn off the power when you move it to avoid damaging the cord and create conditions for a fire. If you damage the power cord, it may cause fire or electric shock.

Do not spill water, liquids or flammable substances (alcohol, benzene, paint thinner, etc.) on the device. If they touch the high voltage areas inside the equipment, they may cause fire or electric shock. If such substances fall on, switch immediately the power off and unplug the electrical outlet. Contact the customer service.

Do not place heavy objects on the device as they may tip over or fall and cause injury.

For safety reasons, turn off power at the main switch if you do not use the device for a long period, e.g. at night or during thunder storms.

Never use chemicals or detergents for cleaning the housing, which may damage the surface of the coating.

The device is not guaranteed for use in places with humidity above 80 %, such as indoor swimming pools, in which case it would be irreparably damaged.

Technology to Advance Education

II CHARACTERISTICS



Output power: 150 W
Power source : 110 / 250 V
Loudspeaker: 15''
Frequencies: 863-865 MHz
Sensibility: 98 dB
Effective range: 25 m
Dimensions:

- Width: 44 cm
- Height: 70 cm
- Depth: 36cm

- Weight: 16 kg
- USB/SD connector
- Audio format: MP3, FLAC, WAV and WMA
- Line IN/OUT: RCA
- Microphone input 1
- Bass / treble adjustment.
- USB and microphones volumes
- Main volume for all sources
- Wireless microphones characteristics:
- Battery: 9V
- Consumption: 90 mA

II.1 SWITCHING ON

For a mains supply use, connect the mains cable, and turn switch ON. The power LED lights green.



Technology to Advance Education

III PARTS DESCRIPTION

III.1 DEVICE Description

Front side:

- | | |
|---------------------|-------------------------|
| (1) Handle | (5) HF microphone stand |
| (2) SD/USB/BT Drive | (6) HF microphones |
| (3) Control board | (7) side handle |
| (4) Trolley block | (8) Wheels |

Non contractual photo



Technology to Advance Education

III.2 CONTROL PANEL:

- (1) Bluetooth USB/SD Drive
- (2) Microphone input jacks
- (3) UHF microphones ON/OFF
- (4) Microphone volume
- (5) LINE IN volume
- (6) USB/SD Bluetooth volume
- (7) Main volume
- (8) Treble / Bass adjustment
- (9) wired microphone socket
- (10) Line IN RCA sockets for external sources
- (11) Line IN XLR socket
- (12) Line OUT socket
- (13) Speaker OUT socket
- (14) ON/OFF switch
- (15) Power cord connection

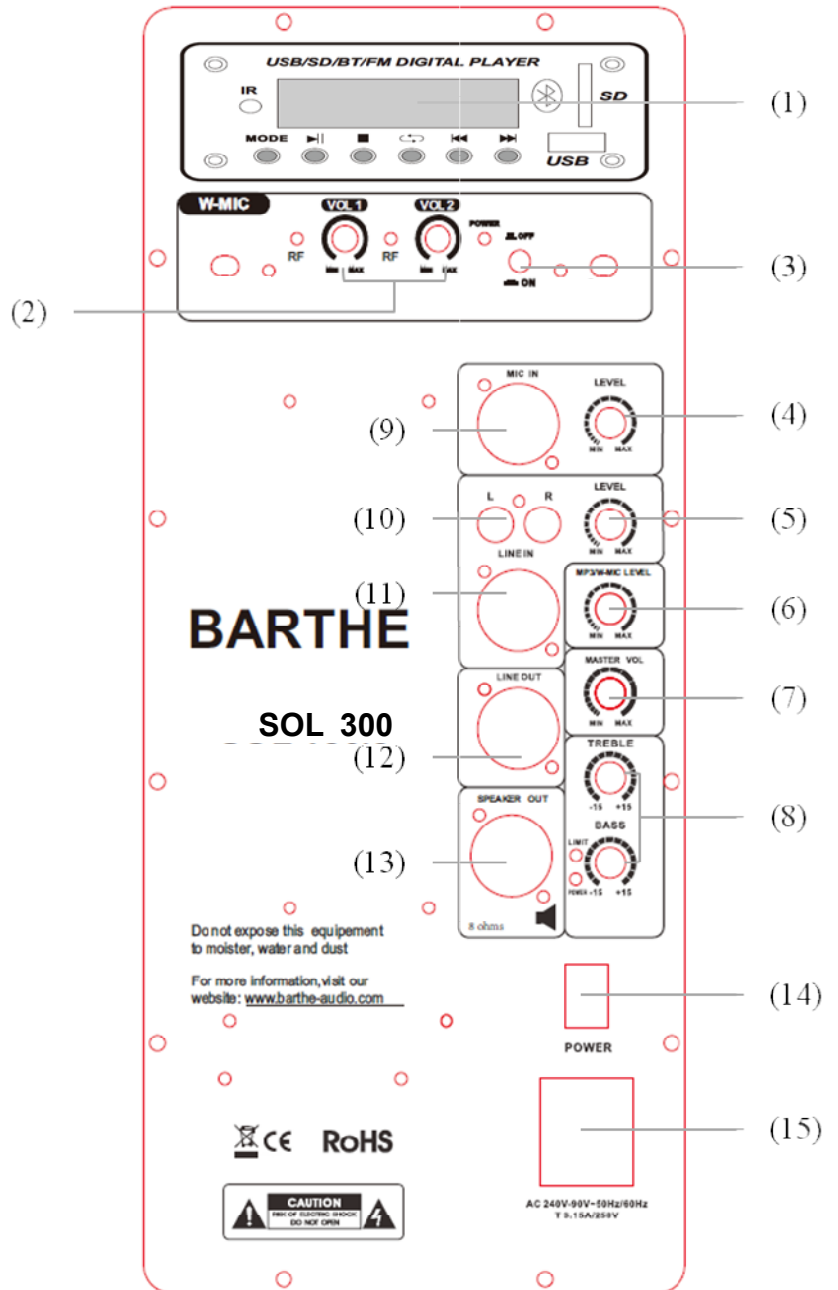

Description:

- LCD display with blue backlight off.
- Repeat mode loop.
- Playback of MP3, FLAC, WAV and WMA files.
- 3 play functions: reading of all songs, repeat a song, reading all songs of the current folder (ALL, 1, or F).

Description of elements:

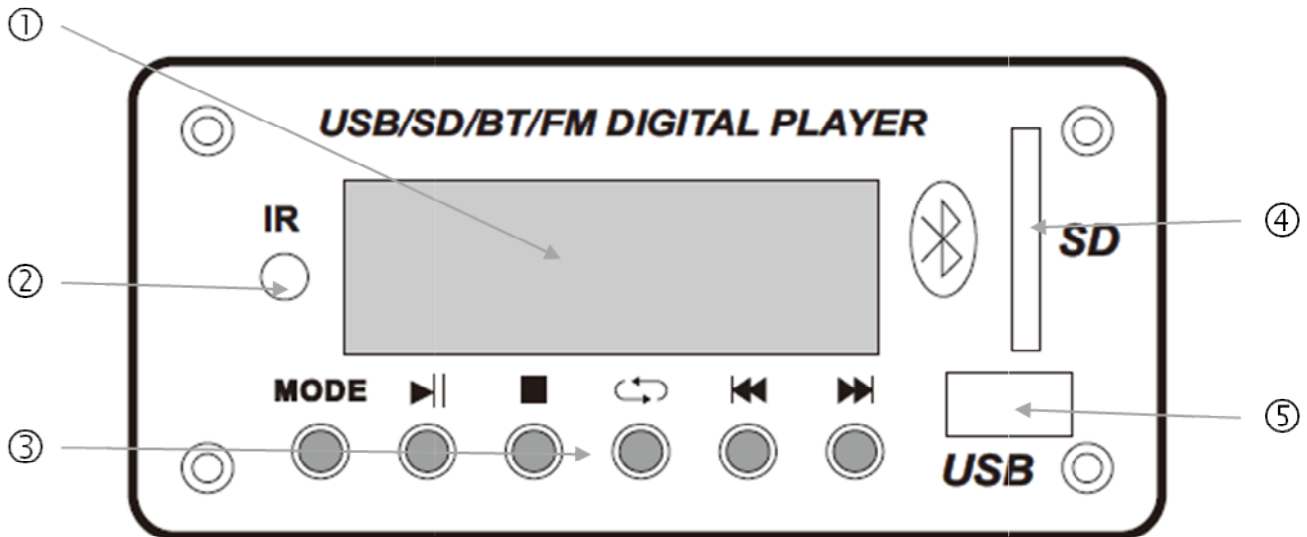

1 LCD Display

4 SD/MMC card reader

2 Infrared receiver

5 USB reader

3 Action buttons

Technology to Advance Education



- 1 Reading status
- 2 Media playback
- 3 Playback mode

- 4 Reading time
- 5 Number of the track
- 6 Track title

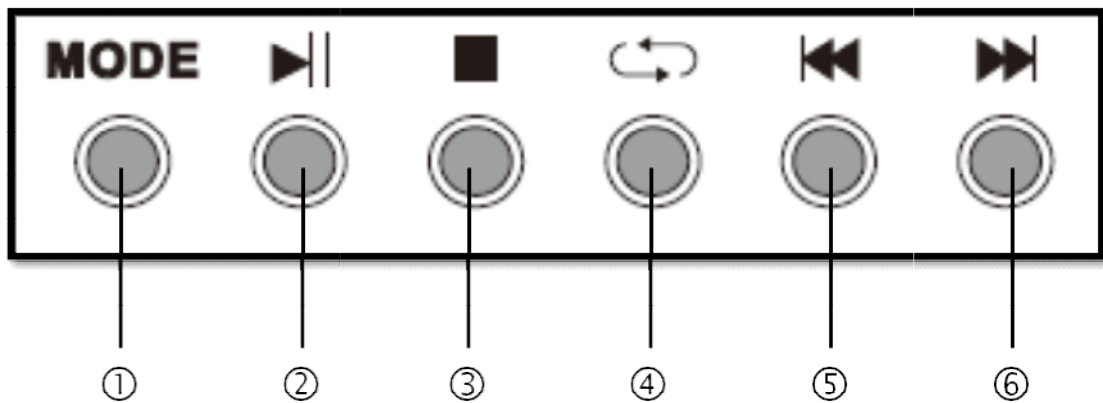

- 1 Mode and standby
- 2 Play/Pause
- 3 Stop
- 4 Playback modes

- 5 Return previous track and Volume -
- 6 Next track advance and Volume +

Technology to Advance Education

HANDHELD MICROPHONE

- (1) Mesh
- (2) Power switch
- (3) Power LED indicator
- (4) Battery compartment

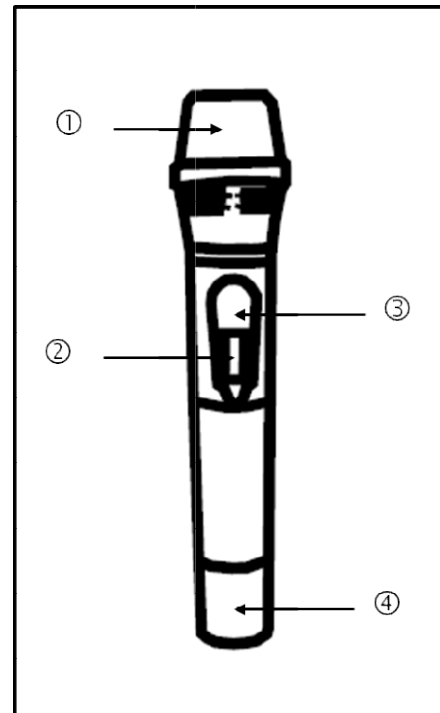

Technology to Advance Education

REMOTE CONTROL

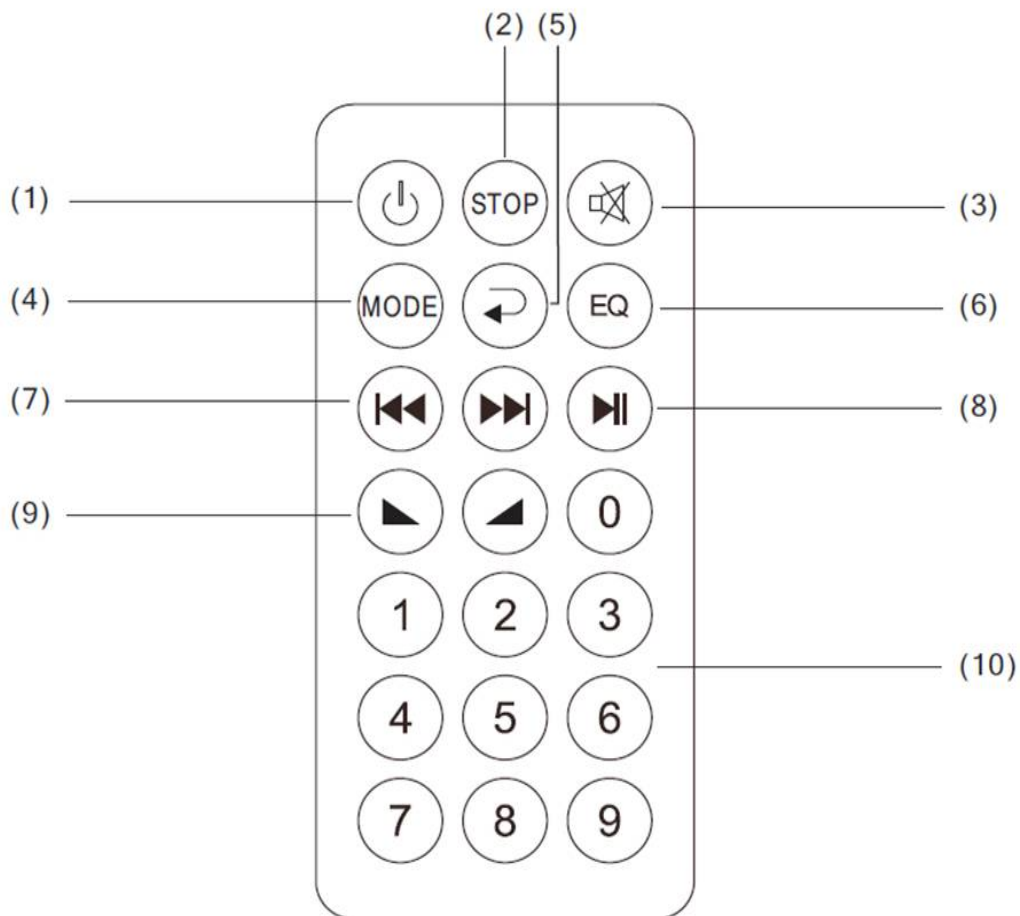

- 1- **POWER:** Switch on or switch off the drive
- 2- **STOP:** N/A
- 3- **MUTE:** Mutes the sound of the player.
- 4- **MODE:** Allows you to select the source.
- 5- **RETURN:** Returns to the previous function.
- 6- **EQ:** Equalizer
- 7- **PREVIOUS/NEXT:** Switches to a track or chapter, below or above.
- 8- **PLAY/PAUSE:** Allows you to play or pause.
- 9- **VOLUME +/-:** Adjusts the volume of the player.
- 10- Selection of tracks, chapters, by dialling, (ex: press 9 to access track 9).

Technology to Advance Education

IV. USE

IV.1 GENERAL USE

This device can be used on mains supply or on battery (if battery option).

- Using the device on mains supply

Plug the cord of the device on the AC input and on an electrical outlet.

Press ON, ON indicator lights, the unit is ready for use.

To use a wired microphone, plug the microphone into the MIC IN (2) and adjust the volume (12).

To use an external amplifier, connect the LINE OUT (5).

To amplify the sound from an external source, connect the cable to line (4) and adjust the volume.

- Using the device on battery



When using the device on battery, unplug the device and switch it on. The LED (22) lights on.

If the battery is not sufficiently charged, the device turns off automatically.

Connect the device to the mains, the device will automatically charge.

IV.2 MP3 DRIVE

Adjusting volume:

During playback press the button  to decrease the volume and hold down the button  to increase the volume.

The return to the original interface will be done if no action is performed for 5 seconds.

Standby:

To pause the MP3 player press and hold the MODE button for 3 seconds.

Selecting the media:

To read a SD/MMC card or a USB device, simply connect it and playback starts automatically to switch between media, press the MODE button.

Bluetooth function:

To select Bluetooth, press on the MODE button until to have the Menu Bluetooth, start searching for devices on your device to connect, select the device named « Bluetooth ».

To return to the NORMAL mode, press on the MODE button until you select the desire media.

Playback mode:

To the change the play mode, press on button ,



A Loop all tracks in order on the selected media.



D Loop playback of all tracks in the selected folder.



1 Loop playback of selected track.



R Loop playback.

Technology to Advance Education

Starting play:

- 1- Press PLAY/PAUSE to play the selected file.
- 2- Press gain to pause playback.
- 3- During playback, press PREVIOUS to go to the previous track.
- 4- During playback, press NEXT to skip to the next track.

IV.3 HAND WIRELESS MICROPHONE

1. Open the battery compartment of the microphone, insert the batteries (please take care of the polarity).
2. Set to ON, The LED indicator lights up.

V REPAIRS

Repairs must be performed by qualified technicians. The device must be repaired as soon as it has been damaged.

Fuse replacement:

If it is necessary to replace the mains fuse, remove the fuse compartment located above the outlet, throw away the old fuse and use rescue fuse that is in the compartment.

Only use 3,15A, 250V fuses.



Technology to Advance Education

- Accessories supplied with the device

1. Power cable
2. Remote control
3. Emitter : HH : micro handheld (depending on model)
2 batteries AA depending on model
4. User guide

VI QUESTIONS

Double check the following points before concluding that your system is down.

- 1- Are all connections correct?
- 2- Is the system used in accordance with the instruction manual?

If the system is not working properly, perform the check list below. If any of these checks does not resolve the problem, the system may be defective. Then immediately unplug the power cord and contact your dealer.

SYMPTOME	CAUSE	SOLUTION
The device does not turn on when you press the power switch.	<ul style="list-style-type: none">- The power cord is not properly plugged into the wall outlet.- The main plug is not working- The mains voltage does not match the device's specification.- Blown fuse.	<ul style="list-style-type: none">- Plug the power cord into the wall outlet.- Call an electrician.- Obtain an adapter.- Replace the fuse (see section « cleaning »).
The device does not react to the action of keys.	<ul style="list-style-type: none">- The switch is in the Off position.- The device is not connected.	<ul style="list-style-type: none">- Turn the switch On.- Disconnected and reconnected the device.
There is no sound.	<ul style="list-style-type: none">- The level of the command of the general volume is insufficient.- The level of the volume control of the source is insufficient.	<ul style="list-style-type: none">- Adjust the volume control on the right position.- Adjust the volume control on the right position.
The wireless microphone is not working.	<ul style="list-style-type: none">- The battery is installed in the wrong direction.- The battery is too low.	<ul style="list-style-type: none">- Replace the battery in the right direction.- Put a new battery with a proper voltage.
The wire microphone is not working.	<ul style="list-style-type: none">- The microphone is in position « off ».- The microphone is not connected.	<ul style="list-style-type: none">- Press the key « on ».- Disconnect and reconnect the microphone input « micro » of the device.

Technology to Advance Education

VII REGULATION

This device complies with the standards applicable in the EU.

It complies with:

- Directive 2002/95/EC of the European Parliament and of the Council of January, 27th 2003 on the restriction of the use of certain hazardous substances in electrical and electronic equipment (RoHS).
- The Low Voltage Directive 2006/95EC
- The EMC Directive 2004/108/EC

This product is guaranteed for 2 years parts and labour, except in case of use not complying with the instructions in this manual and excluding accessories and battery.

Accessories are guaranteed for one year.

Batteries are guaranteed for 6 month.



Notes on environmental protection:

In accordance with European Directive 2002/96/EC, and to achieve a number of environmental objectives, the following rules must be applied. They are related to electrical and electronic equipment waste. The pictogram on the product, its user manual or packaging indicates that the product is subject to these regulations. Consumers should return the used product to collection points for this purpose. They can also give it to a reseller. In allowing the recycling of products, consumers will contribute to the protection of our environment. It's an ecological act.

Distributed by



M025EA

11 rue des Sapeurs – 34 380 St Martin de Londres - FRANCE –

Phone: +33 04 67 55 14 57 – Fax: +33 04 67 63 54 95

www.barthe-audio.com - info@barthe-audio.com

Limited Company with a capital of 202 000 € - 572 029 155 RCS Montpellier – 2640 Z –

Reg. Number: FR 46 572 029 155